

INSTALLATION INSTRUCTION AND SERVICE MANUAL

Actuator/Trailer Dealer - Please provide these instructions to the consumer.
Consumer - Read and follow these instructions. Keep them with the trailer for future reference.

TITAN **MODEL 6** SURG-O-MATIC ACTUATOR FOR TRAILER BRAKES

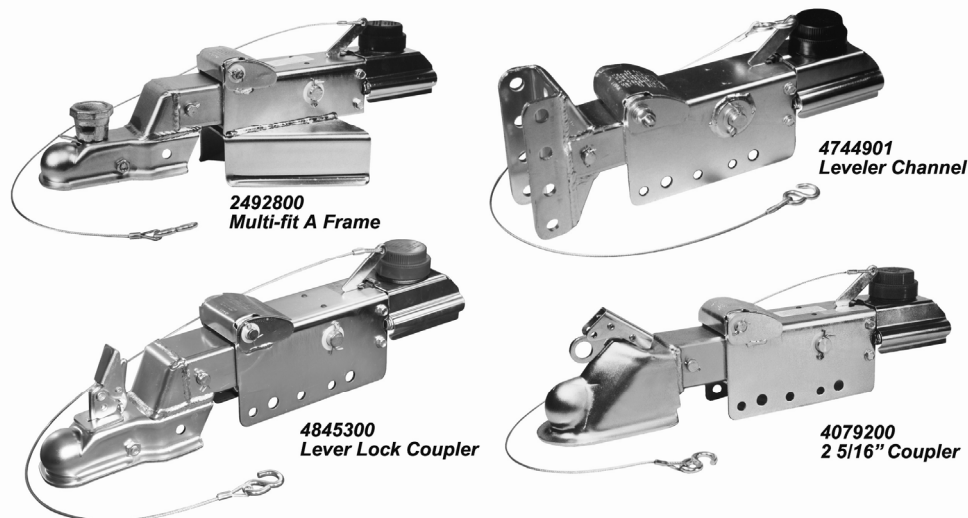

Surge actuators of this type provide a service life of approximately five years with proper installation, usage, and maintenance. However, a well cared-for actuator can often exceed this estimate. To get the most benefit from your TITAN surge actuator, follow the instructions given in this manual and use common sense in caring for the TITAN MODEL 6 actuator and your entire trailer brake system.

RATED CAPACITY AND USAGE

⚠ WARNING ⚠
DO NOT exceed these ratings

8,000 POUNDS MAXIMUM GROSS LOAD with 2 5/16" bolt-on coupler, **7,500 POUNDS MAXIMUM GROSS LOAD** with 3" lunette eye or leveler channel or A-Frame in lunette or 2 5/16". This is the weight of the trailer fully loaded with all cargo and equipment. To find your trailer's Gross Load, use a commercial vehicle scale at a truck weigh station, grain elevator, etc.

6,000 POUND MAXIMUM GROSS LOAD with 2" multi-fit ball coupler.

800 POUND MAXIMUM TONGUE LOAD with 2 5/16" bolt-on coupler, **600 POUND MAXIMUM TONGUE LOAD** with other Model 6 actuators. This is the weight applied downward by the fully loaded trailer's coupler on the tow vehicle's hitch. Measure your trailer's Tongue Load with the tongue in a horizontal towing position, using a commercial scale. Upward tongue loads are not permissible.

The Model 6 actuator is intended for use with recreational trailers subject to more frequent use, light utility trailers, and light occasional-use industrial trailers, which are towed by passenger cars and pickups. The actual in-service rating is limited to that of the ball and hitch being used or the trailer manufacturer's G.V.W.R. shown on the certification label, whichever is lower.



A Titan Company
2345 East Market Street
Des Moines, IA 50317
800-USA-BEAR or 800-872-2327
FAX 515-265-9301

INSTALLATION

⚠ WARNING ⚠

DO NOT submerge the actuator. Internal corrosion may result and cause brake failure. Salt water, granular fertilizers, and other corrosive materials are destructive to metal. To minimize the damaging effect of corrosion on a braking system used under corrosive conditions, we recommend that the actuator be externally flushed after use with a high pressure water hose. Be sure to lubricate all moving parts after the unit has dried. Whenever the unit will be out of service for an extended period of time, or after hard use, remove the brake drums and clean inside the brakes. Pack wheel bearings with grease before the drum is installed. Failure to properly and adequately grease and maintain the actuator could weaken it and/or cause it to fail and result in serious injury and/or property damage.

Surge braking requires the installation of an actuator at the tongue of the trailer.

The "surge" or "push" of the trailer toward the tow vehicle automatically synchronizes the trailer brakes with the tow vehicle brake. As the trailer pushes against the tow vehicle the actuator telescopes together and applies the force to the master cylinder, supplying hydraulic pressure to the brakes.

The Model 6 Actuator is completely assembled and ready to bolt or weld into place.

1. Bolt or weld the actuator to the tongue. Light weight tongues require spacer tubes inside for reinforcement when bolting. Attachment strength should equal 1-1/2 times trailer G.V.W.R.
2. Install hydraulic brake lines on the trailer as described in the installation manual supplied with the brakes. Be sure to use a flexible hose when connecting the master cylinder to the hydraulic line on the trailer. This is necessary because the master cylinder is spring mounted to provide overload protection.

⚠ WARNING ⚠

Failure to complete the "BRAKE FLUID FILLING AND BLEEDING" procedures promptly after installation may result in internal master cylinder corrosion and cause brake failure.

⚠ WARNING ⚠

Use only fresh brake fluid from a sealed container. DO NOT reuse fluid. After filling and bleeding, remember to refill the actuator. Failure to maintain an adequate fluid level may cause brake failure.

3. Fill the system with DOT 3-4 heavy duty brake fluid using a vacuum type or pressure type brake bleeding system. Both types of brake bleeding systems should be available at your local automotive jobber. Follow the manufacturer's instructions.

Brake Fluid Filling and Bleeding

- 3a. After completing the "Installation" instructions, remove the master cylinder cap and fill the reservoir to three-quarters full with DOT 3-4 brake fluid. DO NOT allow brake fluid to contact painted surfaces since it will damage the finish. Wipe up any spills immediately and wash the area with water.
- 3b. If you choose to manually bleed the system, an assistant makes the job easier. Please note the diagram in figure 1 (on the next page). Disconnect the trailer from the tow vehicle and hook the safety chains (NOT the actuator break-away cable) together to form a loop. The loop should be centered below the actuator's coupler as shown in Figure 1.
- 3c. Place a sturdy board such as a 2 x 4 into the safety chain loop below the coupler. The board should be four feet long or more so it will extend well above the actuator. Position the board to press against the front end of the actuator's coupler and use it to force the coupler case into the actuator's outer housing. This pumps the brake fluid into the trailer braking system. Manually pull the coupler case back to fully extended position and repeat the process.

INSTALLATION (cont.)

Brake Fluid Filling and Bleeding (cont.)

- 3d. When the air bubbling stops inside the master cylinder, install a bleeder hose on the bleeder screw of the first wheel cylinder or disc brake caliper to be bled. Be sure to use the bleeder screw on top of the caliper. Start with the rear axle on tandem axle trailers. Submerge the other end of the hose in a glass container of clean brake fluid so that air bubbles can be observed. Open the bleeder screw one turn before pushing the coupler case in. When the coupler is pushed completely in, the bleeder screw should be closed to prevent air from being pulled back into the system. Air trapped in the brake lines will greatly reduce your braking efficiency. Repeat this process until no more bubbles are released with each stroke. Be sure to close the bleeder screw securely.

⚠ WARNING ⚠

DO NOT use the actuator's break-away lever or cable to bleed the brake system.

- 3e. Repeat the bleeding operation at each wheel cylinder. During the bleeding process, replenish the brake fluid so the level does not fall below half full level in the master cylinder reservoir. When bleeding is complete, fill the reservoir to within 3/8" of the top. Install the filler cap securely.

TESTING TITAN SURGE BRAKE SYSTEMS

⚠ WARNING ⚠

It should be noted that the field-test procedure indicates only if the trailer brake system is functional, but DOES NOT provide information on how efficiently it will operate. Regular inspection, maintenance, and adjustment of all brake system components (including the surge actuator, tubing, hoses, brake clusters, drums or disc brake calipers and rotors and associated hardware/support structure) are still required to ensure maximum brake performance and smooth, even brake operation.

1. Hydraulic surge actuator systems provide automatic and smooth trailer braking without special application by the tow vehicle driver. While this is extremely convenient it can sometimes be difficult to determine if the surge setup is functioning properly. The following steps provide a quick field-test to confirm that the trailer brake system is operational.
2. Move the trailer to flat, level ground, pulling FORWARD several feet before parking. This forward motion will ensure trailers equipped with free-backing brakes are in their normal operating mode. Disconnect the trailer from the tow vehicle and jack the trailer's tongue until it is horizontal.
3. Hook the trailer's safety chains (NOT the actuator's break-away cable/chain) together to form a loop, which is centered below the actuator's coupler as shown in Figure 1.
4. Place a sturdy board, such as a 2 inch by 4 inch piece of lumber, into the chain loop below the coupler. The board should be 4 feet or longer so it will extend several feet above the actuator. Keep the end of the board a few inches off the ground, and position it to press against the front end of the actuator's coupler.
5. Stand in front of the trailer and face the rear. Apply force to the top end of the board to use it as a lever. Press back towards the rear of the trailer. The board will begin moving the coupler case (inner slide) into the actuator's outer housing.

FIG. 1 - FIELD TEST SETUP

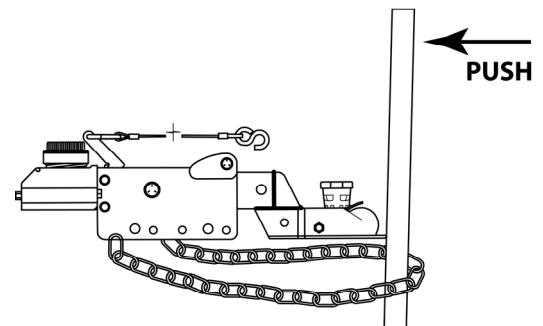

TESTING TITAN SURGE BRAKE SYSTEMS (cont.)

6. Keep pressing the top of the board to stroke the actuator and its internal master cylinder. If the trailer brake system is operational, the brakes will apply and keep the trailer from rolling away from you. Properly adjusted uni-servo or duo-servo type brakes will prevent you from moving the trailer back more than a few inches. Free-backing type brakes will initially provide rolling resistance, but continued force on the board will switch them into free-backing mode, and you'll be able to move the trailer backwards.
7. If you have uni-servo or duo-servo brakes, and stroking the actuator (as described previously) causes the trailer to roll away from you freely or with only minimal resistance, the brakes are **NOT** applying properly. If you have free-backing brakes, and stroking the actuator (as described previously) causes the trailer to roll away without initial resistance, the brakes are **NOT** applying properly. The brake system **MUST** be evaluated to determine the cause of the problem, and corrective action **MUST** be taken before the trailer is used.
8. Use this procedure each time you tow your trailer to check your surge brake system operation.

⚠ WARNING ⚠

To ensure proper engagement of the actuator's coupler to the tow ball, **DO NOT** use a multi-piece ball, an incorrectly sized ball, or a worn/damaged ball.

HITCHING TRAILER

1. The towing hitch and ball must have a rating equal to or greater than trailer GVWR.
2. Multi-fit Ball coupler will accept 1-7/8", 50MM and 2" trailer balls. Tighten hand wheel to secure ball in socket. Make certain ball latch is in correct position to retain the ball, and that the hand wheel lock is clicking while tightening. You must depress the lock to loosen hand wheel in order to un-hitch trailer. Do not tow trailer if coupler is damaged (see Figure 3 on page 5).
3. Connect safety chains using crossed pattern under tongue, or follow trailer manufacturer's directions (see Figure 2 on page 5).

⚠ WARNING ⚠

An incorrect lever or chain position may cause the trailer brakes to drag and overheat, or may keep the brakes from being applied in a break-away situation. After any usage of the break-away mechanism, either real or accidental, check all system components (lever, cable, S-hooks, catch spring and pin, push rod assembly, etc.) for damage. Replace any damaged items with genuine TITAN service parts.

4. Connect break-away S-hook (see Figure 2 on page 5).

⚠ WARNING ⚠

The trailer safety chains' length **MUST** be set short enough so the actuator's break-away cable is **NOT** pulled if the coupler separates from the tow vehicle's hitch but remains connected by the safety chains. The break-away system should only be activated after **BOTH** the trailer's coupler **AND** safety chains have failed and allowed the trailer to completely separate from the tow vehicle. Provide just enough slack in the trailer safety chains to allow tight turns. The chains should not drag on the ground. Safety chains must be used.

5. The break-away system should only operate after both the coupling and safety chains have failed. The break-away is not a parking brake.

⚠ WARNING ⚠

The break-away system is not designed to operate if the trailer does not separate completely from the tow vehicle, or if the trailer tongue "submarines" and goes beneath the tow vehicle. **DO NOT** use the break-away system as a parking brake.

HITCHING TRAILER (cont.)

6. **Resetting the Break-away Lever:** (Refer to the parts diagram on page #9) When the break-away lever (item 7) is engaged, it is in the vertical position. It must be reset before the trailer is moved. First, carefully loosen the pressure line fitting to the master cylinder to relieve hydraulic pressure (Figure 3 below). Then remove the four bolts (item 10) that secure the master cylinder assembly to the outer case (Figure 3 below). The flat front tab of the "U" shaped break-away spring (item 9) can then be placed in the top notch of the break-away lever. Then position the back tab of the break-away spring on the top of the master cylinder mounting bracket (item 12) as you line up the master cylinder assembly bolt holes. Tighten the bolts and check the break-away lever position – it should be at about a forty five degree angle (Figure 3 below). Tighten the brake line fitting and re-bleed the brakes as necessary.

⚠ WARNING ⚠

The hydraulic pressure held in the system may cause the lever to snap back quickly. Keep hands and fingers clear as you reset the break-away mechanism.

7. Sway control devices that restrict operation of the actuator cannot be used. The actuator must be free to telescope in response to braking requirements.

FIG. 2 - SAFETY CHAIN AND BREAK-AWAY CABLE ATTACHMENT
(top view shown)

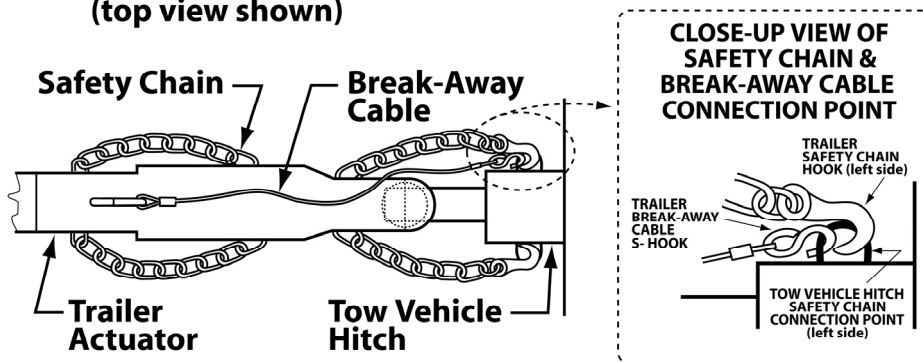

8. If the break-away lever and cable are not located correctly as described above, due to either the cable being pulled during use or by accident, it **MUST** be reset prior to the trailer being moved.
9. When this actuator is used with disc brakes or non free-backing brakes, our solenoid back up valve part number 4748800 will allow the trailer to be backed without activating the brakes. Do not block actuator movement in and out to back up the trailer. Failure to remove the blocking device will prevent **all** trailer braking.

FIG. 3 - BREAK-AWAY LEVER

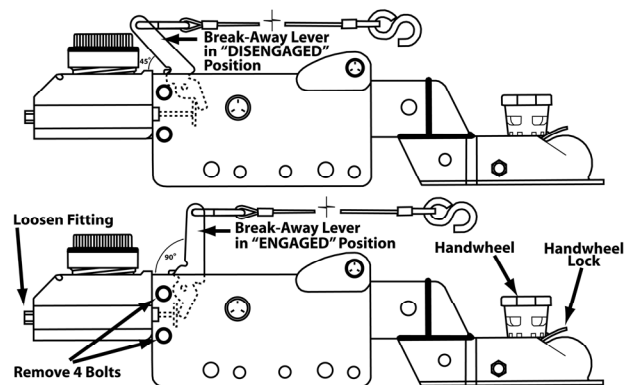

⚠ WARNING ⚠

An incorrect lever or chain position may cause the trailer brakes to drag and overheat, or may keep the brakes from being applied in a break-away situation. After any usage of the break-away mechanism, either real or accidental, check all system components (lever, cable, S-hooks, catch spring and pin, push rod assembly, etc.) for damage. Replace any damaged items with genuine TITAN service parts.

MAINTENANCE

1. Before towing check that brake fluid reservoir is at least half full. If not, re-fill to 3/8 inch below the top of the reservoir with DOT 3-4 brake fluid. Check for leaks and repair as required.
 - Check that the brake fluid reservoir is three-quarters full of DOT-3 or DOT-4 brake fluid. Check for leaks and repair as required.

⚠ WARNING ⚠

Use only fresh brake fluid from a sealed container. DO NOT reuse fluid. After filling and bleeding, remember to refill the actuator. Failure to maintain an adequate fluid level may cause brake failure.

- Examine the actuator for wear, bent parts, corroded/seized parts, or other damage. Have the affected components replaced with genuine TITAN service parts. Check to determine that the actuator mounting bolts (where applicable) are tightened to eighty (80) foot-pounds torque using a torque wrench.
 - Test the actuator and brake function as described in the "TESTING TITAN SURGE BRAKE SYSTEMS" section of this manual. Actuator travel over one inch indicates that the brakes need adjustment (or that the actuator has been structurally damaged). Actuator travel is the distance the coupler case assembly <2> moves relative to the outer case <1> during braking. Adjust the brakes following the instructions given in the brake installation manual. In general, back off adjusters ten clicks from locked drum rotation. Adjust free-backing brakes by rotating in the forward direction only. Failure to adjust brakes will result in loss of braking.
2. A film of grease on the hitch ball will extend coupler and ball life while eliminating squeaking. Wipe clean and renew film each time trailer is used.
 3. Before towing, examine the actuator for bent parts or wear. Replace parts as necessary. Check to determine that mounting bolts are tight and welds not cracked.
 4. There are no adjustments on the actuator.
 5. Actuator travel (over one inch) shown by front roller path indicates a need to adjust the brakes. Adjust per instructions found in brake installation manual. In general, back-off adjusters 10 clicks from locked rotation. Adjust Free-Backing brakes by rotating in forward direction only. Failure to adjust may result in loss of braking.
 6. Before storage or after extended use, TITAN recommends applying motor oil to the coupler components, lockout mechanism, and the three internal rollers to keep them moving freely and to prevent corrosion.

MODEL 6 ACTUATOR PRODUCT LIST

Part # Drum	Part # Disc	Description	Inner	Outer
4079200		2 5/16" coupler	4067700183	2480100183
	4747200	2 5/16" coupler	4067700183	2480100183
	4747210	2 5/16" coupler with cover	4067700183	2480100183
	4747220	2 5/16" coupler w/valve and cover	4067700183	2480100183
4079200317		2 5/16" coupler	4067700317	2480100317
4067600		2 5/16" coupler, A frame	4067700183	2493000
4093200		3" lunette eye	4045600183	2480100183
	4748000	3" lunette eye	4045600183	2480100183
4045500		3" lunette eye, A frame	4045600183	2493000
2480000		2" multi fit coupler	4391600	2480100183
	4747900	2" multi fit coupler	4391600	2480100183
2492800		2" multi fit coupler, A frame	4391600	2493000
4845300		2" leverlock coupler	4845200	2480100183
	4845400	2" leverlock coupler	4845200	2480100183
4744900		leveler channel	4745100317	4717600317
	4748100	leveler channel	4745100317	4717600317
4744901		leveler channel	4745100183	4717600183
	4748101	leveler channel	4745100183	4717600183
4022300		multi fit coupler	4391600	2493201
4057900		less coupler, A frame	1776900	2493000
1777401		master cylinder w/ mtg brackets		
	1777405	master cylinder w/ mtg brackets		

* NOTE: <#> is the reference number shown in the assembly diagram of the actuator located at the end of this manual

MODEL 6 ACTUATOR PARTS LIST

(ref. diagram on page 8)

	Key No.	Part No.	Description	Qty Reqd.
	1A	2480100183	Outer Case Assy	1
	1B	2493000	A-Frame Outer Case	1
	2	1242700	Bearing, 0.075" thick	2
	3	1776300	Front Roller	1
	4	1776600	Front Roller Pin	1
	5	0799700	Cotter Pin 1/8 x 3/4	2
	6A	1776700	Front Roller Cover #6000	1
	6B	4350700183	Front Roller Cover #7500	1
	6C	4655900183	Front Roller Cover #8000	1
	7	4594100	Break-away Lever w/Pin	1
	8	1055500	S-Hook - Part of 4594100	1
	9	1780300	Break-away Spring	1
	10	1781500	Hex Bolt 5/16 x 1/2 Self Tapping	4
	11	1861900	Washer, nylon	1
x	12	1776200	Cylinder Mounting Plate	1
x	13	1027300	Hex Bolt 3/8 x 5 NC	2
x	14	4390500	Push Rod Assy	1
o	15	2496400	Lock-Ring	1
x	16A	1027100	Master Cylinder - Drum Brake	1
x	16B	4747000	Master Cylinder - Disc Brake	1
x	17	1755600	Master Cylinder Cap, diaphragm type	1
x	18	1209800	Orifice Connector, 0.015", drum brake use	1
x	19	0797600	Nut - Hex 3/8 NC	2
x	20	0782000	Washer 3/8	2
x	21	1027400	Spring	2
	22	1242600	Damper	1
	23	0829100	Rear Roller	2
	24	1777300	Master Pin	1
	25	0815200	Cotter Pin	1
	26	1777200	Damper Pin	1
	27	4391600	Inner Slide w/ Ball Latch, Bolt and Locknut	1
	28	1831600	Washer	1
	29	1806600183	Cover	1
o	30	2338100	Latch Bolt, Multifit Coupler	1
o	31	1809000	Lock Plate	1
o	32	4335800	Ball Latch	1
o	33	4336800	Compression Spring	1
o	34	2338300	Hand Wheel Lock	1
o	35	2420000	Hand Wheel	1
o	36	2339000	Bolt - Hex 7/16 x 2-5/8 NF	1
o	37	2339100	Locknut - 7/16 NF thin	1
	38	4045600	Inner Slide w/3" Lunette Eye	1
	39	4067700183	Inner Slide w/2-5/16" Coupler	1
		1502600	Master Cylinder Repair Kit	1
		4045400	Multi-Fit Coupler Repair Kit	1
		1848700	2-5/16" Ball Coupler Repair Kit	1
	40	4748800	Solenoid Backup Valve	1
	41	4836800183	Backup Valve Cover (plated)	1
x	These parts are included in the master cylinder assembly # 1777401 & 1777405			
o	These parts are included in the 4045400 Coupler Repair Kit			

MODEL 6 PARTS DIAGRAM

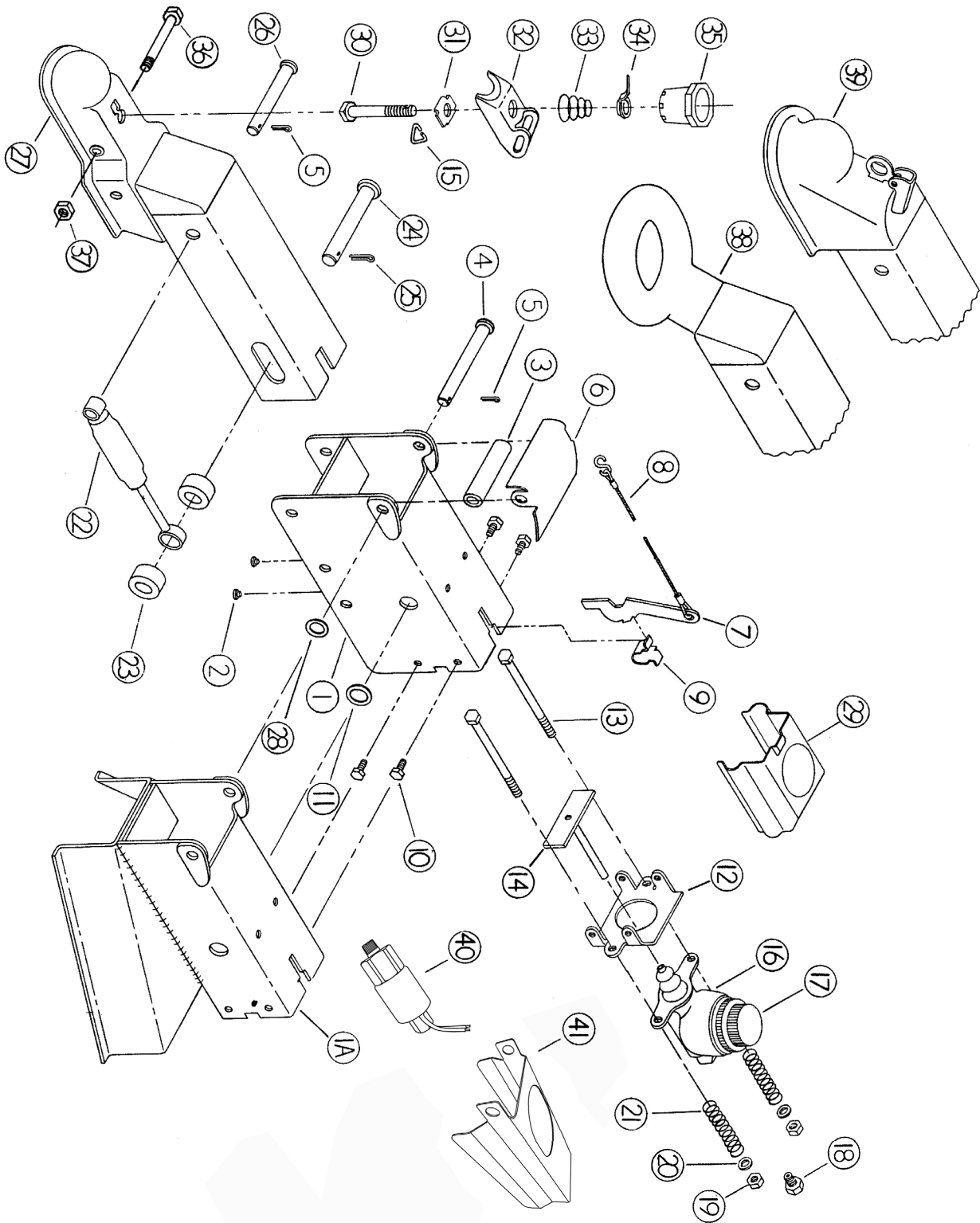



LIMITED WARRANTY

Limited Warranty Titan Tire Corporation (TITAN) warrants its products to be free from defects in material and workmanship for one year from date of delivery to the original purchaser when properly installed, used and maintained by the purchaser.

This warranty does not apply to damage or loss caused by any or all of the following circumstances or conditions:

- Freight damage.
- Parts, accessories, materials or components not obtained former approved in writing by TITAN.
- Misapplication, misuse and failure to follow the directions or observe cautions and warnings on installation, operation, application, inspection or maintenance specified in any TITAN quotations, acknowledgements, sales literature, specification sheet or installation instructions and service manual ("applicable literature")

If any TITAN products are found upon TITAN's examination to have been defective when supplied, TITAN will either: credit the purchaser's account for the purchase price of the TITAN product; or repair the product. TITAN has sole discretion in choosing which option to provide. For this LIMITED WARRANTY to apply, TITAN must receive notice of the alleged defect within 30 days of either the discovery of the alleged defect or the expiration of the warranty period, whichever is earlier. Any claim not made with in this period shall conclusively be deemed waived.

If requested by TITAN, purchaser shall return the alleged defective product to TITAN for examination at Titan's direction and expense. TITAN will not pay for expenses incurred in returning a product to TITAN without TITAN'S prior written authority. TITAN shall not be liable for any other expenses purchaser incurs to remedy any defect. Purchasers waive subrogation on all claims under any insurance.

Limitation of Liability It is expressly agreed that the liability of TITAN is limited and TITAN does not function as an insurer. THE REMEDIES SET FORTH IN THIS WARRANTY SHALL CONSTITUTE THE EXCLUSIVE REMEDIES AVAILABLE TO THE PURCHASER OR USER AND ARE IN LIEU OF ALL OTHER REMEDIES, EXPRESS OR IMPLIED. THE LIABILITY OF TITAN, WHETHER IN CONTRACT, IN TORT, UNDER ANY WARRANTY OR OTHERWISE, SHALL NOT EXCEED THE PURCHASE PRICE OF THE PARTICULAR PRODUCT MANUFACTURED, SOLD OR SUPPLIED BY TITAN.

To Obtain Technical Assistance To enable TITAN to respond to a request for assistance or evaluation of customer or user operation difficulty, please provide at a minimum the following information by calling 1-800-872-2327 or within Iowa 1-515-265-9200:

- Model number, serial number and all other data on the specific component which appears to be involved in the difficulty.
- The date and from whom you purchased your TITAN product.
- State your difficulty, being sure to mention at least the following: Application, Nature of load involved, and Weight of the load.

Field Service If field service at the request of the purchaser is rendered and the difficulty is found not to be with TITAN'S product, the purchaser shall pay the time and expense (at the prevailing rate at the time of service) of the seller's field representative(s). Charges for service, labor and other expenses that have been incurred by the purchaser, its customer or agent without prior written authorization of TITAN will not be accepted.

TITAN EXTENDS NO WARRANTY, EXPRESS OR IMPLIED, ON PRODUCTS NOT MANUFACTURED BY TITAN OR TO TITAN'S DESIGN SPECIFICATION, INCLUDING BUT NOT LIMITED TO SUCH ITEMS AS NON-TITAN TIRES, BRAKES, ACTUATORS, BEARINGS, HOSE AND TUBING, PURCHASER'S RECOURSE SHALL BE LIMITED TO ANY WARRANTY OF THE PERSPECTIVE MANUFACTURERS.

THIS WARRANTY EXCLUDES ALL IMPLIED WARRANTIES OF MERCHANTABILITY OR FITNESS FOR A PARTICULAR PURPOSE OR ANY PURPOSE.

THIS WARRANTY DOES NOT COVER NOR EXTEND TO INCIDENTAL OR CONSEQUENTIAL DAMAGE. Some states do not allow the exclusion or limitation of incidental or consequential damages, so the above limitation or exclusion may not apply to you.

No representative has authority to make any representation, promise or agreement except as stated in this Limited Warranty. TITAN reserves the right to make design and other changes upon its products without any obligation to install the same on any previously sold or delivered products.

THERE ARE NO WARRANTIES WHICH EXTEND BEYOND THOSE DESCRIBED ABOVE. EFFECTIVE JANUARY 1, 1998 THIS WARRANTY SUPERSEDES ALL PRIOR WARRRANTIES, WRITTEN OR IMPLIED.